



Clutch/brake Units type *RotaStep*

Datasheet

5-2000

Description

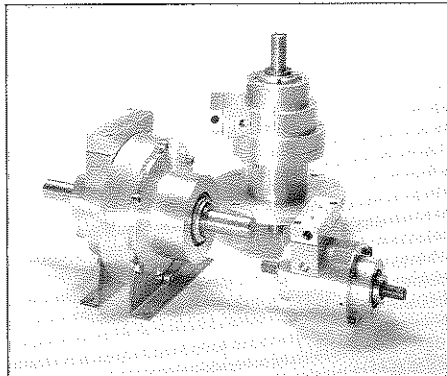

The Rotastep is the ideal solution for precise positioning stop-start applications where short reaction times and repeat accuracy are important.

Features of the Rotastep include:

- Wide torque range
- Adjustable torque of the individual unit
- Long service life, no adjustments necessary
- Solid or hollow input/output shaft to fit standard motors, gearboxes and pulleys
- Flexible family of electronic controls

Typical applications are :
dosing, cutting, packing, thermoforming,
printing, sorting, labelling, stamping.

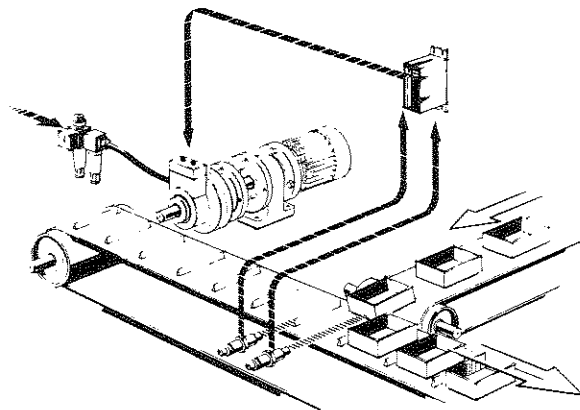

Fig.1

Fig. 1 shows the Precision Step System being used to control a continuous flow packaging line. The Rotastep stops a conveyor belt when a photocell registers a "package missing" from the feed belt and it is held in this position until packages are registered on the feed belt. By using the compressed air actuated Rotastep the system is maintenance free throughout its long service life. (up to 300 million cycles can be obtained).

The Rotastep unit is part of the Laurence, Scott & Electromotors Precision Step System which comprises:

- Rotastep & SRA clutch/brake unit
- SRB electronic control
- SRC signal sources

External signal sources (proximity sensors, photocells, encoders) give start and/or stop signals to electronic control units.

These flexible control units are adaptable for various functions e.g.pulse counting, signal suppression, compensation of external influences etc. Complex microprocessor controls are also available through software.

Mode of operation

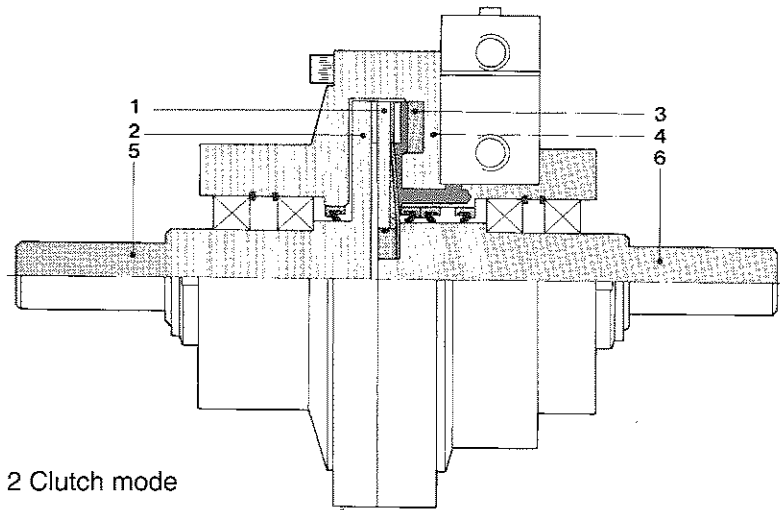

Fig. 2 Clutch mode

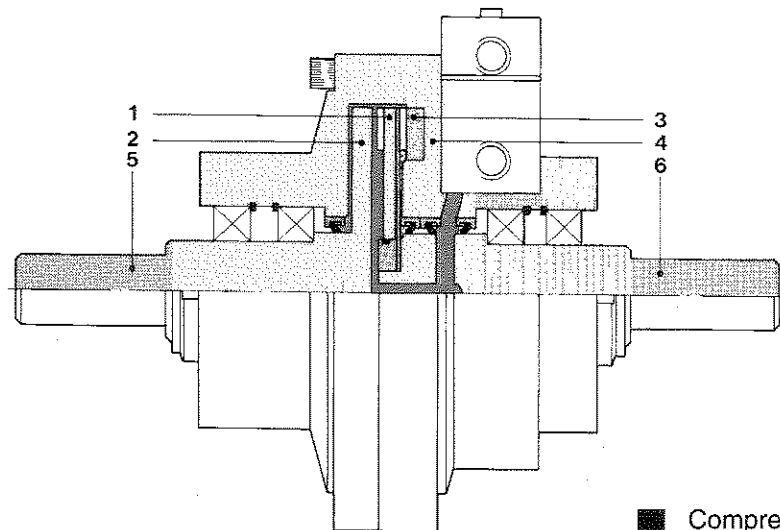

Fig. 3 Brake mode

■ Compressed air circuit

1. Friction disc
2. Clutch disc
3. Brake ring
4. Housing
5. Input shaft (clutch side)
6. Output shaft (brake side)

The Rotastep unit is actuated by compressed air

Two solenoid valves direct the compressed air to the clutch and brake side, respectively.

Fig. 2 shows Rotastep in clutch mode . Fig. 3 shows Rotastep in brake mode.

When neither of the solenoid valves are activated, normal pressure prevails on both the clutch and the brake side. The clutch shaft (item 5) and brake shaft (item 6) can rotate freely.

Rotastep
Data

Rotastep size	06	08	10	12	15
Static torque M_s [Nm] Compr. air Δp 1-3 bar	$\geq M_k$	$\geq M_k$	$\geq M_k$	$\geq M_k$	$\geq M_k$
Dynamic torque, M_k [Nm] Compr. air Δp 1-3 bar	3 - 9	6 - 18	12 - 36	22 - 66	40 - 120
Max. number of revolutions, n_{max} [rpm]	1800	1800	1800	1800	1800
Max. heat dissipation, P_{max} [W]*	50	80	120	160	200
Inertia of Rotastep, I_R [kgm ² x 10 ³]	0.10	0.43	0.85	1.56	2.9
Reaction time t_{r1} [s x 10 ³]	10	13	15	17	20
Max. time taken to reach full dynamic torque, t_{r2} [s x 10 ³]	6	7	8	9	10
Nominal friction work, W_R [J x 10 ³]	50	144	215	324	464
Internal volume, V_R [10 m ³]	39	59	73	99	122
Ambient temperature [°C]**	0 - 40	0 - 40	0 - 40	0 - 40	0 - 40
Grade of enclosure [IP]	54	54	54	54	54
Weight [kg]	3.6	5.0	7.4	7.9	11.9

The repeat accuracy is constant during the service life.

* Note ! $n \geq 1200$ rpm requires $P \leq P_{max} \times \frac{1200}{n}$

** Up to 60°C depending on heat dissipation.
Surface temperature on Rotastep : 100°C max.

Torque
range

The product range consists of 5 different Rotastep sizes:
Rotastep 06,08,10,12,15.
Combined, these cover a torque range (dynamic torque) of 3 to 120 Nm, see fig. 3. Activated by compressed air, the Rotastep requires an inlet differential pressure of 1.0 to 3.0 bar. By adjusting the pressure, the torque can be varied. Thus various torque requirements can be covered within the same Rotastep size.

Fig. 4

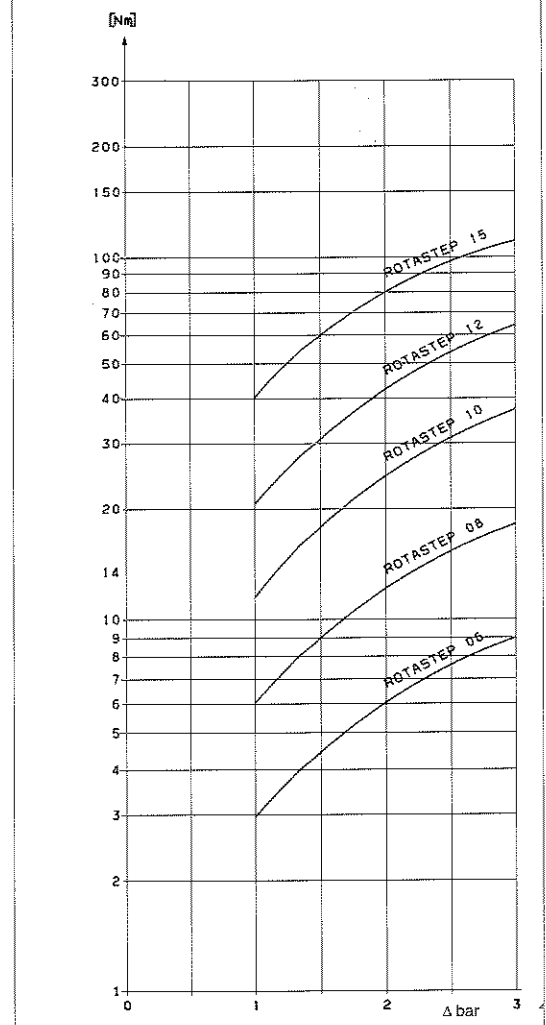

Rotastep types

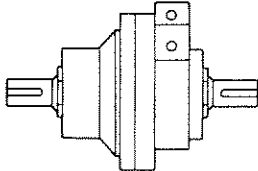
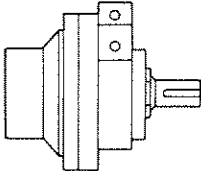
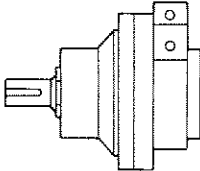
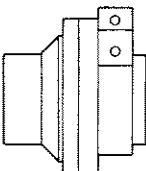
Rotastep sizes 06, 08, 10, 12, 15			
Type 10	Type 20	Type 30	Type 40
Solid/solid shaft	Hollow/solid shaft	Solid/hollow shaft	Hollow/hollow shaft
			

Flanges

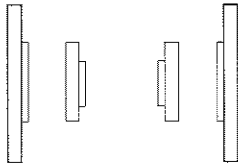
Type B5	internal/external	Form A flanges in accordance with DIN 42948	
Type B14	internal	Form C flanges in accordance with DIN 42948	

Bracket

Bracket for foot mounting	Shaft height in accordance with DIN 747	
---------------------------	---	---

Ordering Table

Rotastep size	Type	Code No	Rotastep size	Type	Code No.
06	10	080H1111	10	30	080H3131
06	20	080H1121	10	40	080H3141
06	30	080H1131	12	10	080H4111
06	40	080H1141	12	20	080H4121
08	10	080H2111	12	30	080H4131
08	20	080H2121	12	40	080H4141
08	30	080H2131	15	10	080H5111
08	40	080H2141	15	20	080H5121
10	10	080H3111	15	30	080H5131
10	20	080H3121	15	40	080H5141

Rotastep 06

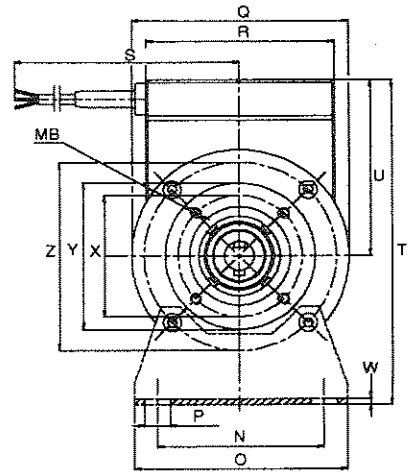
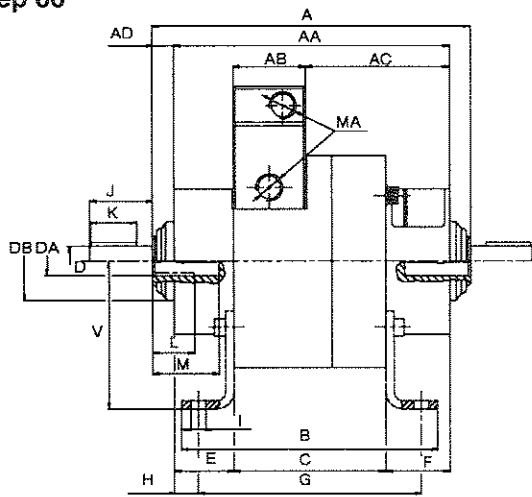

Rotastep 08,10,12 & 15

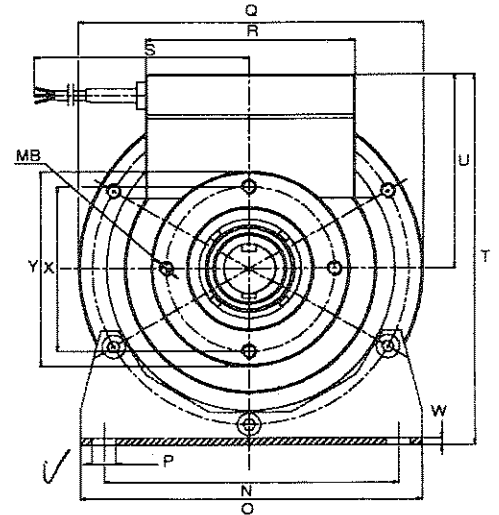
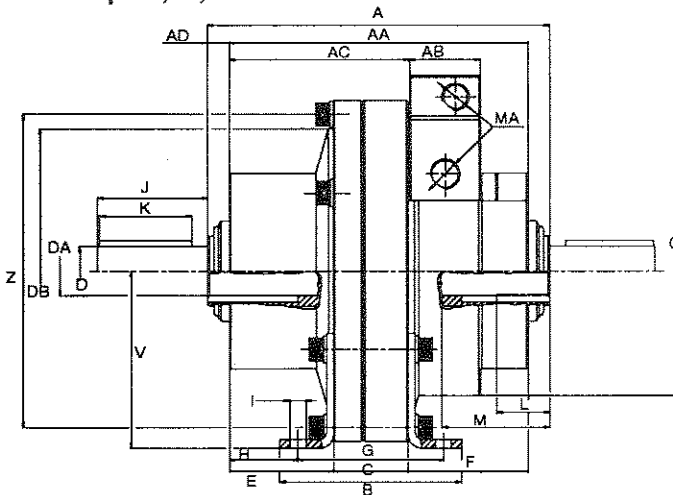

Dimensions

Type	KA	KB	KC	KD
Rota 06	15.95	5	16.35	5
Rota 08	21.5	6	21.8	6
Rota 10	26.9	8	27.4	8
Rota 12	31	8	31.3	8
Rota 15	31	8	31.3	8

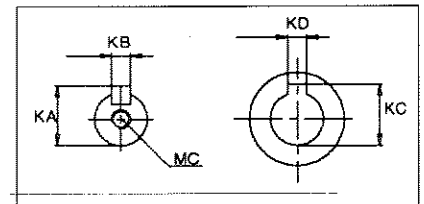

Type	A	AA	AB	AC	AD	B	C	E	F	G	I	J	K	L	M	MA	MB	MC
Rota 06	153	133	35	69.5	10	123.5	73.5	28.5	31	107.5	7	30	22	20	31.5	G1/4	4xM5x15	M5x10
Rota 08	171.9	155	35	94.5	12	151.5	99.5	30	25.5	135.5	7	40	32	25	44	G1/4	4xM6x15	M6x16
Rota 10	187.5	163.5	35	93.5	12	87	37	59	67.5	71	7	50	40	25	51	G1/4	6xM6x15	M6x16
Rota 12	192	168	35	106	12	98	42	40	68	78	7	60	50	30	60	G1/4	4xM8x15	M6x16
Rota 15	192	168	40	101	12	102	42	58	68	82	9	60	50	30	60	G3/8	4xM8x15	M6x16

Type	N	O	P	Q	R	S	T	U	V	W	D	DA	DB	X	Y	Z
Rota 06	78	100	12	102	88.5	1500	155.2	84.2	71	4	14	14	38	58	70	90
Rota 08	90	112	12	115	88.5	1500	176	96	80	4	19	19	87	77	87	103
Rota 10	118	140	12	142	88.5	1500	188	98	90	4	24	24	116	80	92	128
Rota 12	138	165	12	170	88.5	1500	204	104	100	4	28	28	140	93	110	156
Rota 15	163.5	190	13.5	192	116	1500	210	110	100	4	28	28	160	93	110	176

Dynamic torque

t_{11} = Reaction time, time from start/stop signal to the beginning of the torque increase [s]

t_{12} = Maximum time taken to reach full dynamic torque (time to reach max. pressure) [s]

$t_1 = t_{11} + t_{12}$ [s]

t_3 = Acceleration time, time taken to reach full speed [s]

M_k = Dynamic torque of the Rotastep

M_s = Static torque of the Rotastep.

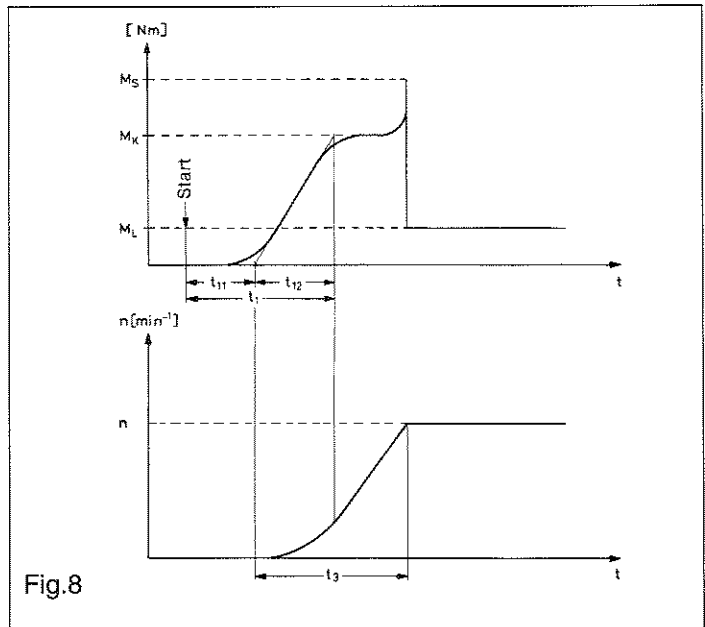

Fig.8

Selection

To select the correct Rotastep size the following must be known :

n = revolutions per minute [rpm]

I = inertia torque, [kgm²]

t_3 = acceleration or deceleration time, [s] (max. 0.025s when high repeat accuracy is required).

F = frictional force [N]

r = radius of feeding roller [m]

Calculation of this data is made on the basis of plant specifications such as measurements of feed rollers, chains etc., cycling frequency, max. feeding length or turning angle and time available per cycle.

The sizing is made according to the formula :

$$M = \frac{\Sigma I \times 2 \times \pi \times n}{60 \times (t_3 - t_{12}/2)} + (F \times r) \text{ [Nm]}$$

Repeat accuracy of the Rotastep is expressed by the time in ms. The tolerance of the required feeding length is the length to be reached in ± 0.5 ms

Example.

$$\Delta s = v \times \Delta t$$

$$v = 1 \text{ m/sec}$$

$$\Delta t = \pm 0.0005 \text{ sec}$$

$$\Delta s = (1 \times 0.0005) \text{ m}$$

$$= 0.5 \text{ mm}$$

External tolerance factors , such as encoder, motor recovery time etc., cannot be accomadated in the repeat accuracy calculation. Sizing examples are available from LSE and the LSE sales engineers are at your service with any required calculation as well as their application experience.

Mounting of
Rotastep

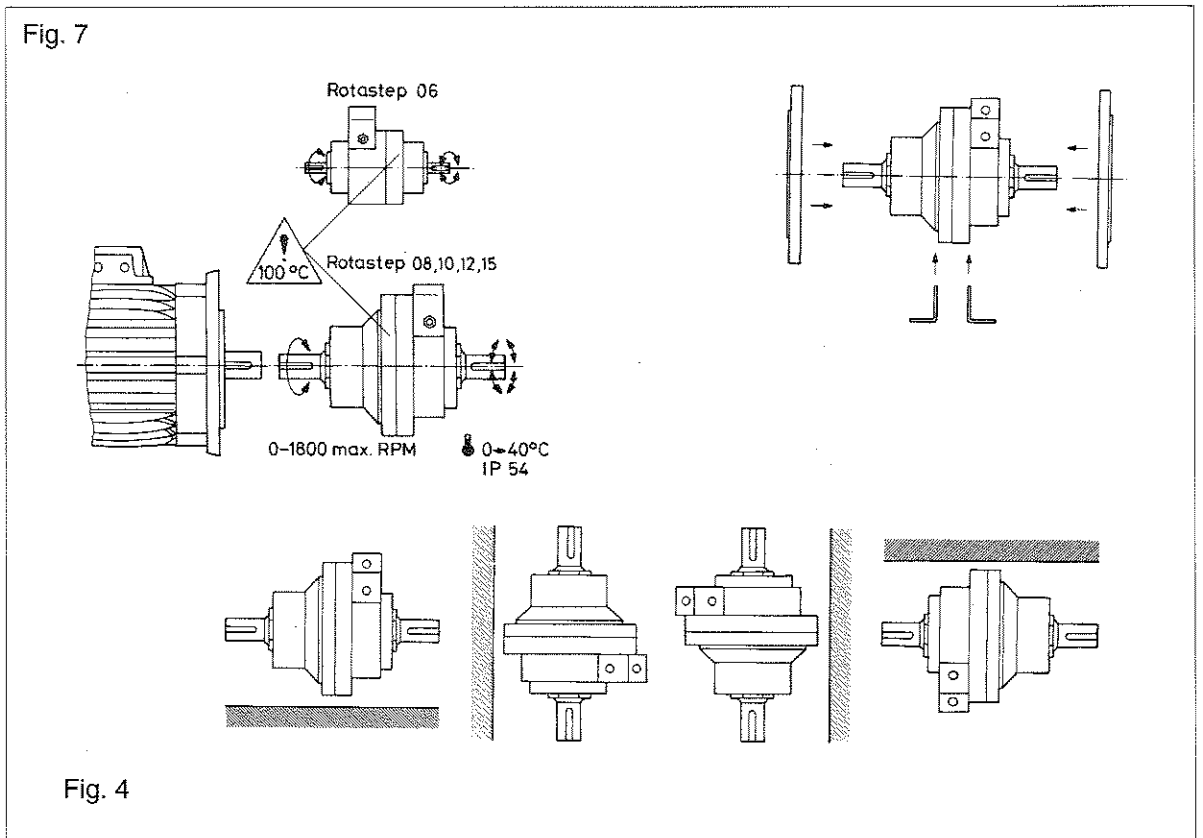

Rotastep is mounted on brackets or with the use of flanges.

The clutch/brake unit can be mounted in any position on a flat surface.

Note ! The valve housing of Rotastep 06 is on the input side where as the valve housing of Rotastep 08, 10, 12 and 15 is situated on the output side.

Permissible shaft loads

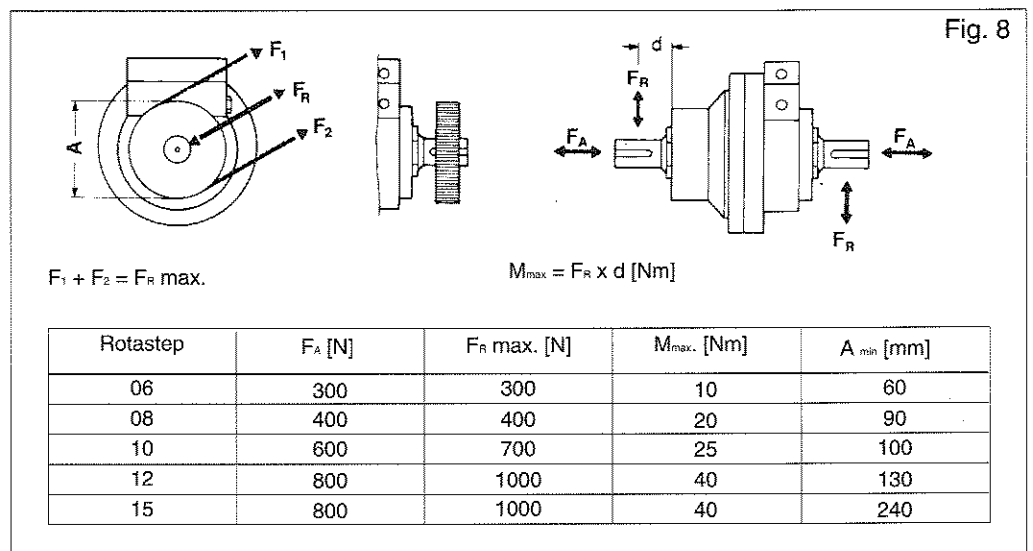

Australia

Danfoss (Australia) Pty. Ltd
1, Ricketts Road, Private Bag 20
Mount Waverley, Victoria 3149
Tel: +612 39 543 1033
Fax: +612 39 543 4027

Holland

Almotion B.V.
Buskesdries, 2A
Andelst 6673 DP
Tel: +31 488 480858
Fax: +31 488 481165
e-mail: Info@almotion.nl

Malaysia

Enmark (M) Sdn.Bhd
Lot 8, Tembaga SD5/24
Bandar Sri Damansara
Kuala Lumpur 52200
Tel: +603 632 3232
Fax: +603 6358069

Belgium

Danfoss N.V.
Erasmus Business Park
Jan Wybranlaan, 45
Brussels B-1070
Tel: +322 5250711
Fax: +322 5250781
e-mail: dick.goossens@danfoss.be

Italy

Mondial S.p.A.
Via Keplero, 18
Milano 20124
Tel: +392 668101
Fax: +392 6889370
e-mail: APGR@mondial.it

Scandinavia

MSW Motion Control ApS
Amstvejen, 44-1, Nybol
Sonderborg DK-6400
Tel: +45 7446 6070
Fax: +45 7446 6071
e-mail: msw@msw-motion.com

France

Mansco S.A.
46, Ave. des Freres Lumiere
ZA Trappes – Elancourt
F78190 Trappes
Tel: +33130 624252
Fax: +33130 690199
e-mail: gerard.mansion@mansco.fr

Indonesia

PT Eltab
JI AM Sangai No. 1
Petojo Utara
Jakarta 10130
Tel: +62 21 6334149
Fax: +62 21 6335753

Spain

Cotirpa S.L.
Calle Sant Elies, 29-35
Esc.B. 1-1
Barcelona E-08006
Tel: +3493 3479135
Fax: +3493 3479766
e-mail: cotirpa@cotirpa.com

Germany (North)

MSW Motion Control GmbH
Schloss-Strasse, 32
Werther D-33824
Tel: +49 5203 5699
Fax: +49 5203 5004
e-mail: v.spiekerkotter@msw-motion.de

Japan

Japan Fawick Ltd
WBG Marive East 19F
2-6, Nakase, Mihama-Ku
Chiba-Shi, Chiba 261-7118
Tel: +81 43 2971800
Fax: +81 43 2971831
e-mail: jf-iba@fawick.co.jp

Taiwan

ACE Pillar Trading Co.Ltd.
No. 12, Lane 61, Sec. 1
Kuanfu Road, San Chung City
Taipei
Tel: +8862 995 8400
Fax: +8862 995 3466
e-mail: angela_lee@acepillar.com.tw

Germany (South)

MSW Motion Control GmbH
Im Himmelreich, 32
Allersberg D-90584
Tel: +49 9176 90450
Fax: +49 9176 90363
e-mail: b.schmid@msw-motion.de

Korea

Unitek Engineering
Seokyoung Building, 201
Daich-Dong, 100-3
Kangnam-Ku, Seoul
Tel: +8202 567 0090
Fax: +8202 569 2894
e-mail: unitekeng@ktnet.co.kr

United States of America

Orbit Motion Technologies Inc.
Unit 15, Madaket Place
766, Route 29
Mashpee MA 02649
Tel: +1 508 539 0100
Fax: +1 508 539 0111
e-mail: orbit@cape.com

United Kingdom

Industrial Clutch Parts Ltd.
Unit 11, Bingswood Industrial Estate
Whaley Bridge
High Peak SK23 7LY
Tel: 01663 734627
Fax: 01663 733023
e-mail: mike@icpltd.co.uk



Laurence, Scott & Electromotors Ltd. – Power Transmission Products (PTP)

PO Box 25, Hardy Road, Norwich, Norfolk, NR1 1JD England
Tel: ++44 (0)1603 628333 Fax: ++44 (0)1603 610604
e-mail: ptp@laurence-scott.com